

TECPak™

585 SERIES

USER'S MANUAL



TEMPERATURE
CONTROLLER

Table of Contents

Introduction	3
Safety Terms and Symbols	4
Quick Start.....	6
Installation	7
Operating Modes	9
Settings.....	10
Arroyo Control.....	14
Front and Rear Panels	15
Connecting to the TECpak	18
Installing the USB Drivers	18
Working With Thermistors.....	19
Working With RTDs	21
User Calibration of Resistance Sensors	23
Controlling the Temperature Rate of Change	24
External Fan Control	24
Resistive Heaters and Heat/Cool Only Modes	25
Gain Control and the PID Loop.....	25
Using the AutoTune Function	26
Compensating for Cable Resistance	27
Using the Analog Interface.....	28
Specifications	33
Error Messages	35
Calibration, Maintenance and Service.....	37

Introduction

Thank you for choosing the **TECPak** from Arroyo Instruments. Your **TECPak** is a combination of leading edge technology combined with years of experience in the field of temperature control, and based on the proven designs found in the **5240** and **5300 Series TECSources**.

The **TECPak** was design for system integration applications, or simply where a user interface like that found on the **5300 Series TECSources** is not required or desired. With high TEC power options, both RS232 and USB computer interfaces, analog interface, and small footprint, the **TECPak** will fit into almost any temperature control application.

TECPak's analog interface provides a way of both controlling and monitoring the state of the instrument, with analog temperature set point, actual temperature monitoring, stable indicator, and on/off control and status. This allows for control in applications that do not have a computer interface.

The **TECPak** offers all the features you would expect from a modern temperature controller, including:

- Support for both thermistor and RTD sensors.
- 4-wire measurement mode for RTD sensors.
- AutoTune for automatic PID parameter calculation
- 0.004°C temperature stability
- 0.01°C resolution for both set point and actual temperatures
- 4A/8V and 5A/12V standard configurations, with custom configurations available

What's in the Box

Along with the **TECPak** itself, a CD with electronic copies of this manual, the **Computer Interfacing Manual**, and USB drivers are included. For USA customers, a power cord is included. For non-USA customers, an IEC-60320-C13 rated AC power cord must be provided.

Accessories

Arroyo Instruments also sells several accessories designed to work with the **TECPak**. These include:

- **1260B TECSource Cable, 5A, 2m**
This cable has DB-15 male/female connectors for interfacing to the LaserMount or other connectorized fixtures, and supports up to 5A of TE current and connections for the fan interface. A pigtailed version of

this cable, with tinned ends for soldering into custom solutions, is available as p/n **1261B**.

- **1262B TECSource Cable, 10A, 2m**
Similar to the **1260B** cable, but adds wiring for 4-wire RTD sense, and therefore only needed for RTD applications. Also adds 10 Amp operating capability. A pigtailed version of this cable, with bare ends for soldering into custom solutions, is available as p/n **1263B**.
- **Pak Series Rack Mount Kit, 3 or 5 units (p/n 1402-RM)**
For installing your **TECPak** or **LaserPak** into a standard 19" rack. The kit accepts either 3 units for a 2U installation, or 5 units for a 3U installation.
- **10k Ω Thermistor (p/n 1600)**
Accurate to $\pm 0.2^{\circ}\text{C}$.
- **RS-232 NULL Cable, 3m (p/n 1200-NULL)**
- **USB Cable, 3m (p/n 1201)**

Safety Terms and Symbols

The following safety-related terms are used in this manual:

- **Warnings** (noted by the WARNING heading) explain dangers that could result in physical injury or death;
- **Cautions** (noted by the CAUTION heading) explain conditions that could result in damage to the instrument, other equipment, or your device.
- **Notes** (noted by the NOTES heading) are *not* safety-related, and are intended simply to point out important information.

If, at any time, any of the following conditions exist, or are suspected of existing, discontinue use of the unit until it can be inspected by qualified service personnel:

- Visible damage to the unit, including damage or stress caused during product shipment;
- Storage of the unit outside the standard storage temperature or humidity rating, or prolonged storage under harsh conditions;
- Failure to operate properly.

If needed, contact your distributor or Arroyo Instruments for service or repair to ensure the safety of the product is maintained.

Symbols



Power Off



Power On



Caution, refer to manual



Earth ground



Caution, risk of electric shock

General Warnings

WARNING

This instrument is intended for use by qualified personnel who understand the shock and laser hazards and are familiar with safety procedures required to avoid injury. Read this manual completely before attempting to use this product.

WARNING

To avoid electrical shock, ensure a 3-prong power cord is used, and is plugged into a earth-grounded receptacle. Failure to do so can result in severe injury or death.

CAUTION

There are no user-serviceable parts inside. All service and repair work shall be done by Arroyo Instruments or personnel authorized by Arroyo Instruments. Modifications done by non-authorized personnel will void the warranty. Please see the Service section later in this manual for instructions on how to obtain service for this instrument.

Quick Start

The **TECPak** was designed with ease of use in mind, and you will likely have little need for this manual for almost all of the features the unit offers. This section will show how you can quickly get the unit up and running in almost no time.

The **TECPak** has a universal input power supply, accepting 90 to 240 VAC, and 50 or 60 Hz. This covers all conventional power worldwide, but ensure your AC power meets these requirements.

Plug the AC cord into the unit and into the wall outlet. Turn on the power switch located on the IPC, and the unit will power up. The AC Power LED should light, and the On / Error LED should remain dark.

Control of the **TECPak** can be done two ways: use the RS232 or USB computer interfaces and control the instrument from the PC, or use the analog interface. This quick start guide uses the computer interface. More information on the analog interface can be found later in the manual.

Install the **Arroyo Control** software located on the CD that came with the instrument (it can also be downloaded from our web site), located in the **Software** folder on the CD. Once the software is installed, plug the instrument into your RS-232 or USB interface. For USB users, the instrument may also ask for drivers, which are also found on the CD.

Launch **Arroyo Control**, and in the TECSOURCE panel (if one is not visible, click Add Panel in the lower right of the window, and click Add a TEC Panel), select the communications port to which your **TECPak** is connected. For USB users, this will usually be the highest numbered port in the list. Click Connect, and **Arroyo Control** will begin controlling the **TECPak**. Once connected, you will be able to adjust settings, limits, and turn the output on or off.

Next, connect the cable between your LaserMount or other fixture and the **Output** connector of the **TECPak**. We recommend using our cables as they have been designed to work well with the **TECPak**. If using your own cables, ensure they have been properly wired according to the pin-out of the **TECPak** and your fixture.

Finally, set the set point to an appropriate temperature and turn the output on. You will see the voltage and current begin driving the fixture to the set point you have chosen. Depending on the thermal size of your fixture, it may take seconds or several minutes to reach the set point.

If you notice the temperature is oscillating around the set point and not stabilizing, you may need to adjust the **Gain** setting in the **Settings...** dialog.

You can use the AutoTune feature to automatically calculate the best PID values, or select from a set of eight factory preset values that typically cover most applications. To use the factory gains, if the temperature is quickly jumping up and down, the **Gain** will typically need to be reduced. If the temperature is slowly moving up and down, try a higher **Gain**. You may need to experiment with several gain settings to find the ideal value, and for even finer control, you can set the **Gain** to *PID* and directly set the PID control values.

Installation

Installation of the **TECPak** is very straightforward, as the quick start section above illustrated. This section will provide additional details and considerations for installing your **TECPak**.

After unpacking the unit, make sure all packing materials have been removed and nothing obscures the ventilation ports on the front and back of the unit.

The **TECPak** has a universal input power supply, accepting 90 to 240 VAC, and 50 or 60 Hz. This covers all conventional power worldwide, but ensure your AC power meets these requirements.

CAUTION

Do not exceed 250VAC on the line input.

It is critical to maintain the proper voltage input into the unit. If the actual voltage exceeds 250VAC, damage to the unit may occur.

Powering Up the Unit

Connect the AC power cord to the unit. Turn the power switch, located on the AC power input power connector, into the on (|) position. The unit will go through a quick power-up self-test, and return to the last known operating state. The AC Power LED will light up, and the On / Error LED should remain dark until the TEC output is turned on (if **Automatic Output On** has been enabled, the On LED may light without user intervention).

Ventilation

The **TECPak** has vent holes on the front and rear of the unit. You must not block these vent holes, or overheating may occur, causing damage to the unit.

CAUTION

Do not operate the unit above +40°C ambient, and ensure the instrument is properly ventilated, or the unit may overheat and possible damage to the instrument may occur.

Rack Mounting

A rack mount kit (p/n 1402-RM) for standard 19" racks is available for the **TECPak**, and supports the rack mount of up to five units in either a 2U or 3U high opening, depending on the orientation of the **TECPak**. Because the units only ventilate from the front and rear, no air gapping is required above or below the units, and they can be rack mounted immediately above other equipment (no rack spacers required).



Warm-up and Environmental Considerations

In order to achieve the highest level of accuracy, the **TECPak** should be powered on for at least one hour prior to taking measurements. In addition, ensure that the unit is not operating outside the ambient temperature range or humidity conditions.

Operating Modes

Control Modes

The **TECPak** offers three control modes: constant temperature mode (T Mode), constant resistance mode (R Mode), and constant current mode (Ite Mode).

Changing the control mode can only be done through the computer interface, either through **Arroyo Control**, or by sending the appropriate TEC:MODE command.

Constant temperature mode uses the sensor constants to calculate the resistance of the sensor at the desired or actual temperature.

While most users will only need the temperature control mode, the constant resistance mode allows you to bypass the sensor equation and directly select the sensor set point. This can be useful when only the desired sensor value is known, or when the sensor-to-temperature conversion values are not available for your sensor.

Using Limits

The **TECPak** supports three different types of limits: temperature, sensor, and current. There is both a temperature high and temperature low limit, and if the actual temperature exceeds either of these limits, the output will be shut off. Likewise, both high and low limits exist for the sensor (R limits), and the output will be shut off if the sensor measurement exceeds either of these limits.

It is important to properly set these limits to protect your device from damage. If you are uncertain on how to set the limits, please consult with your local distributor or directly with the factory.

Settings

All parameters of the **TECPak** can be viewed and changed over the computer interfaces. In addition, the set point can be changed via the analog interface, if it is enabled.

Most parameters can be changed using a standard command, as defined in the *Computer Interfacing Manual* or through the **Settings...** dialog within **Arroyo Control**. Below is a list of the most common settings and the corresponding computer command to change it.

Name	Description	Factory Default	Computer Command
Basic Settings			
Mode	This set the operating mode (<i>T Mode</i> , <i>R Mode</i> , or <i>Ite Mode</i>) of the temperature controller.	T Mode	TEC:MODE
Mount	Specify the mount connected to the TECPak . If using a LaserMount , select the appropriate model. Otherwise, select <i>User Defined</i> .	User Defined	TEC:MOUNT
I Lim	I Lim sets the current limit of the temperature controller. The limit should be set to a value that is suitable for your Peltier device.	3A	TEC:LIM:ITE
Gain	Gain controls the response of the temperature controller. A higher gain value will cause the controller to respond more quickly to the difference between the set point and the actual temperature, while a lower value will cause it to respond more slowly. Select <i>PID</i> for direct access to the PID parameters. Read more on setting gain below.	30	TEC:GAIN
PID P	The proportional term of the PID loop. Will only be available if Gain is set to <i>PID</i> .	1	TEC:P

Name	Description	Factory Default	Computer Command
PID I	The integral term of the PID loop. Will only be available if Gain is set to <i>PID</i> .	0.01	TEC:I
PID D	The derivative term of the PID loop. Will only be available if Gain is set to <i>PID</i> .	0	TEC:D
Sensor	Sets the temperature measurement sensor. Can be <i>Therm 100uA</i> , <i>Therm 10uA</i> , <i>Therm</i> , <i>RTD</i> , or <i>RTD (4-wire)</i> .	Therm 100uA	TEC:SENS
T-Low Lim	T-Low Lim is the lower temperature limit. If operating in T Mode and the actual temperature drops below this value, the output will be turned off. Temperature limits not monitored in R Mode or Ite Mode. Limit monitoring can also be disabled in software (see TEC:ENAB:OUTOFF command).	-99°C	TEC:LIM:TLO
T-High Lim	T-High Lim is the upper temperature limit. If operating in T Mode and the actual temperature rises above this value, the output will be turned off. Temperature limits not monitored in R Mode or Ite Mode. Limit monitoring can also be disabled in software (see TEC:ENAB:OUTOFF command).	125°C	TEC:LIM:THI

Name	Description	Factory Default	Computer Command
R-Low Lim	R-Low Lim is the sensor low limit. If operating in R Mode and the actual sensor measurement drops below this value, the output will be turned off. R limits are not monitored in Ite Mode. Limit monitoring can also be disabled in software (see TEC:ENAB:OUTOFF command).	0.01kΩ	TEC:LIM:RLO
R-High Lim	R-High Lim is the sensor high limit. If operating in R Mode and the actual sensor measurement exceeds this value, the output will be turned off. R limits are not monitored in Ite Mode. Limit monitoring can also be disabled in software (see TEC:ENAB:OUTOFF command).	45kΩ	TEC:LIM:RHI
Tol Time	Tolerance time is the amount of time, in seconds, that the actual temperature must be within the set point temperature +/- the Tol Temp value for the unit to be considered in tolerance.	5 seconds	TEC:TOL
Tol Temp	Tolerance temperature is a temperature band (in °C) around the set point temperature. When the actual temperature is within this band for longer than the Tol Time setting, then the unit is considered to be in tolerance.	0.1°C	TEC:TOL
H/C Mode	This selects the heating and/or cooling mode of the TECPak . See the section below titled “Resistive Heaters and Heat/Cool Only Modes” for more information.	Heat/Cool	TEC:HEATCOOL

Name	Description	Factory Default	Computer Command
Ext Fan	This selects the voltage for the auxiliary fan power supply. See the <i>External Fan Control</i> section below for more information.	Off	TEC:FAN
Ext Fan Pwr	When Ext Fan is set to <i>Custom</i> , this sets the specific fan voltage from 4.0 to 12.0 volts. See the <i>External Fan Control</i> section below for more information.	12.0	TEC:FAN
Ext Fan Mode	Controls when the fan operates. See the <i>External Fan Control</i> section below for more information.	Auto	TEC:FAN
Ext Fan Off	When Ext Fan Mode is set to <i>Delay</i> , this setting defines the number of minutes to delay turning off the fan after the TEC output has been turned off. See the <i>External Fan Control</i> section below for more information.	5 minutes	TEC:FAN
Cable R	The resistance of the cable and connectors, in ohms. This setting allows for accurate voltage measurement at the TEC by removing the voltage loss of the cable.	0.0080 Ω	TEC:CABLER
T Rate	Selects a desired temperature ramp rate in degrees Celsius per minute. Set to 0.0°C/min to disable rate limiting.	0.0°C/min	TEC:TRATE
Sensor Settings			
Therma	A term in thermistor equation.	1.12924E-03	TEC:CONST
ThermB	B term in thermistor equation.	2.34108E-04	TEC:CONST
ThermC	C term in thermistor equation.	0.87755E-07	TEC:CONST
RTD A	A term in the RTD equation.	3.98480E-03	TEC:CONST
RTD B	B term in the RTD equation.	-0.58700E-06	TEC:CONST

Name	Description	Factory Default	Computer Command
RTD C	C term in the RTD equation.	4.00000E-12	TEC:CONST
RTD R ₀	R ₀ term in the RTD equation.	100.00	TEC:CONST
Communications Settings			
Baud	This sets the baud rate for the RS232 serial port. See the Computer Interfacing Manual which is included on the CD that accompanied this product.	9600	N/A, fixed at 9600
Err While Rmt	To turn off the display of errors while in remote mode, set this value to "No". To display errors while in remote mode, set this value to "Yes".	Yes	REMERR
Terminal Mode	Terminal mode simply echoes any characters received over the serial or USB interfaces.	No	TERMINAL
Msg Term	This controls the output message termination, and can be set to CR/LF, CR, LF, or None.	CR/LF	TERM

Arroyo Control

While most of the settings of the **TECPak** can be changed over the computer interface using your own program (see the *Computer Interfacing Manual* for more detail), in many cases you simply want to operate the instrument from the PC like any other bench-top instrument.

As mentioned earlier in this manual, **Arroyo Control** is a free software application that gives you 100% operating control of the **TECPak**, allowing you to change limits, settings, and set points, as well as monitor the operation of the instrument. From **Arroyo Control**, you can also enable the analog interface, and set the precision of the analog set point. You can install **Arroyo Control** from the CD or download it from our web site (go to the Software section).

Front and Rear Panels

The **TECPak** features four connections (in addition to the input power connector). They are: USB, RS-232, analog, and output connectors. The first three are located on the front of the unit, while the output connector is located on the rear of the unit. In addition, the front of the unit has the input power connector and two status LEDs.



TECPak Front Panel



TECPak Rear Panel

TEC Output Connector

The Output connection is a female DB-15, and has the following pin-out:

DB-15 Pin	Description
1, 2, & 9	TE (+)
3, 4, & 10	TE (-)
5 & 6	Earth Ground
7	Sensor+
8	Sensor-
11	Fan+
12	Fan -
14	Remote Sensor+*
15	Remote Sensor-*

Output Connector (DB-15 Female)

* Used in RTD 4-wire operation only.

NOTE

RTD and fan functionality is only available on TECPaks with serial number 130203819 or higher.

Analog Interface Connector

The Analog Interface connection is a male DB-15, and has the following pin-out:

DB-15 Pin	Description
1	On/Off Control Input
2	On/Off Status Output
3	Stable Output
4	Analog Temperature Monitor
5	Analog Temperature Set*
6	Ground
7	+5V Auxiliary Supply
8	Ground

Output Connector (DB-15 Female)

* Disabled when in RTD 4-wire measurement mode.

The +5V auxiliary supply is provided for external low-power electronics. Current draw on this supply should not exceed 100mA. The Ground pin provides the ground reference for the logic and analog inputs as well as the auxiliary power supply. The analog interface is described in detail in the *Using the Analog Interface* section below.

USB Connector

The USB connector is a standard Type B female connector, and can be plugged into any USB 1.1 or USB 2.0 port. For more information on using the USB interface, see the **Computer Interfacing Manual** which is included on the CD that accompanied this product.

RS232 Connector

The RS232 connection is male DB-9 connector wired in a NULL modem configuration.

Pin	Description
2	Receive
3	Transmit
5	Ground
1,4,6	Commoned together
7,8	Commoned together
9	No connection
Shell	Earth ground

RS232 Connector (DB-9 Male)

For more information on using the RS232 interface, see the **Computer Interfacing Manual** which is included on the CD that accompanied this product.

LED Indicators

There are two LEDs: the upper green AC Power LED that is lit whenever the AC power is turned on; and a lower green or red On/Error LED that will light green when the unit is on and operating normally, or red when an error has occurred. If the unit is operating, but has unacknowledged errors, then the On/Error LED will be primarily green, but briefly flash red approximately once per second to indicate the unit is operating normally, but previously encountered an error (errors are automatically cleared by **Arroyo Control**, or can be cleared by sending an ERR? or ERRSTR? query).

Connecting to the **TECPak**

Arroyo Instruments carries two cable assemblies specifically designed for connecting the **TECPak** to temperature controlled fixtures or devices. The **1260B** or **1262B TECSOURCE Cable** (not included) is a two meter cable, designed for use with Arroyo Instruments mounts and has DB-15 connectors on both ends, one male and one female. The **1262B** is typically only used for applications requiring the 4-wire RTD measurement mode.

For custom applications, a two-meter cable with a male DB-15 on one end and stripped and tinned leads on the other is available as part number **1261B** or **1263B**.

NOTE

Connections to the **TECPak** and the fixture must be secure. Tighten any screws on the DB-15 connectors, and make sure all connections are in good condition.

See the manual for your fixture for additional safety and operational information.

Installing the USB Drivers

Using the **TECPak** via USB is just as simple as using the serial port. In fact, once you have installed the USB drivers, the instrument will appear as a virtual serial port that you can use just like a normal serial port.

To install the drivers, simply plug in the instrument to your computer. When the Add New Hardware wizard appears, insert the CD you received with the **TECPak** and follow the on-screen instructions.

Once the drivers are installed, to determine the COM port number, go to **Control Panel** and select **System**. Once the **System Properties** dialog appears, choose the **Hardware** tab then click on the **Device Manager** button. When the **Device Manager** appears, click on the plus sign to the left of **Ports**. The port identified as an **USB Serial Port** is the **TECPak**. In the event you have multiple **TECPak** instruments plugged in simultaneously, you will need to experiment to see which instrument was assigned to which port. For example, you could change the set point when the output was off to see which unit's set point changed.

Working With Thermistors

The **TECPak** is designed to work with negative temperature coefficient (NTC) thermistors, such as the BetaTHERM 10K3A1 thermistor used in the **LaserMounts**. A thermistor works by translating temperature into resistance, with resistance decreasing as temperature increases (hence the 'negative coefficient').

Here is a typical response curve of a thermistor:

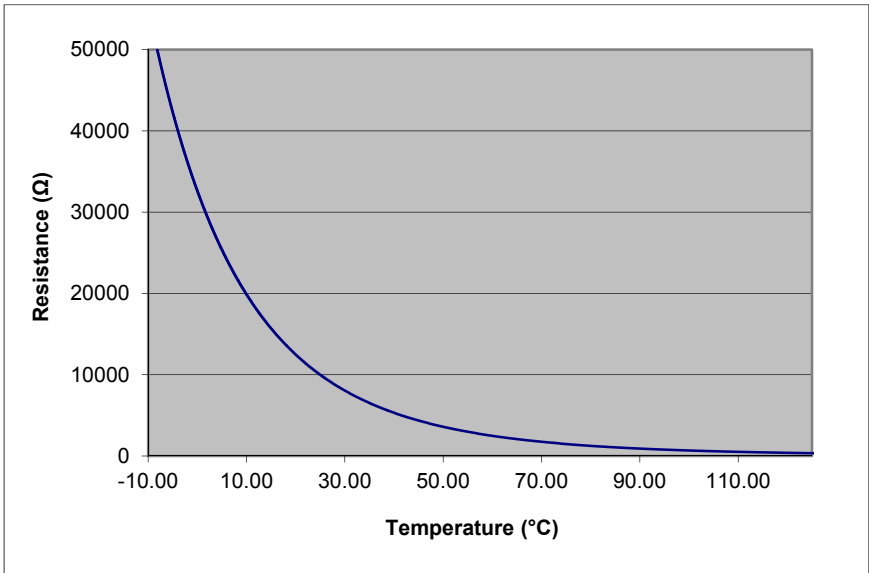

Typical Resistance vs. Temperature Graph

As can be seen by the graph, the resistance of the thermistor drops very quickly. In the typical control range (0°C to 70°C), typical 10K thermistors offer good sensitivity to changes in temperature, and this is the range in which most 10K thermistors are typically used. 10K thermistors can be used at much higher temperatures, but will suffer poorer temperature stability performance because of the lower sensitivity. When evaluating the performance of a thermistor, it is important to understand the resistance sensitivity of the thermistor at your application temperature, which varies greatly by temperature and thermistor types.

The **TECPak** supports operation using a 10µA or 100µA constant current source, which limits the upper control range to 450kΩ and 45kΩ, respectively. To minimize noise and maximize stability, you should select highest current while still allowing you full operation across your required temperature range. The typical setting is 100µA, but your application will determine the actual needs.

The Steinhart-Hart Equation

As can be seen from the temperature versus resistance graph above, resistance varies inversely with temperature in a non-linear fashion. This relationship can be accurately modeled by polynomial equations, and one such being the Steinhart-Hart equation:

$$\frac{1}{T} = A + B * \ln(R) + C * \ln(R)^3$$

The coefficients A, B, and C can usually be obtained from the thermistor manufacturer. The **TECPak** defaults to the coefficients for the BetaTHERM 10K3A1 thermistor (A = 1.12924x10⁻³, B = 2.34108x10⁻⁴, C = 0.87755x10⁻⁷). You can change the coefficients using the TEC:CONST command, or through the **Settings...** dialog within **Arroyo Control**.

Working With RTDs

Like thermistors, RTDs also function by converting temperature into resistance, but unlike thermistors, RTDs increase in resistance as temperature increases. RTDs are also a fairly linear device, meaning they can be used across a much broader temperature control range.

According to IEC751, the resistance/temperature relationship is determined using one of two equations, dependent on the temperature or resistance value being measured. For resistances above the R_0 value (resistance at 0°C, typically 100Ω) of the RTD, the following equation is used:

$$R = R_0(1 + AT + BT^2)$$

Below R_0 , an additional term is added to the equation:

$$R = R_0[1 + AT + BT^2 + C(T - 100)T^3]$$

In both of these equations, R_0 is the resistance of the RTD at 0°C, and A, B, and C are the coefficients as defined by IEC751, through regression analysis, or by using the Callendar-van Dusen method. By default, the TECSource uses the Laboratory standard coefficients, which are for a 0.003926Ω/Ω°C curve (A = 3.9848x10⁻³, B = -0.58700x10⁻⁶, C = 4.0000x10⁻¹², and $R_0 = 100$).

The **TECPak** automatically determines which equation to use based on the conditions at the time of the measurement.

2-Wire versus 4-Wire Measurements

One concern in using RTDs are their relatively low resistance (typically 100Ω at 0°C), and small $\Omega/^{\circ}\text{C}$. Because of these two factors, the resistance of the cable used to connect to the sensor can become a significant error in the sensor measurement. The **TECPak** offers two RTD measurement modes: a conventional two wire measurement mode, which is subject to this error, and a four wire measurement mode that uses separate sensor and source lines to remotely sense the actual resistance of the RTD and eliminate the cable or connector resistances.

When using 4-wire measurement mode, you must select 'RTD (4-wire)' as the sensor type, and then connect the Sensor+ and Remote Sensor+ at one side of the RTD, and Sensor- and Remote Sensor- to the other side of the RTD. Make these connections as close to the sensor as possible.

The drawings below illustrate how 2-wire and 4-wire connections work. Note that 4-wire measurements require all four wires to be brought through the cable to the mount. The **1262B** and **1263B** cables carry this connection through to the mount, but the **1260B** and **1261B** cables do not.

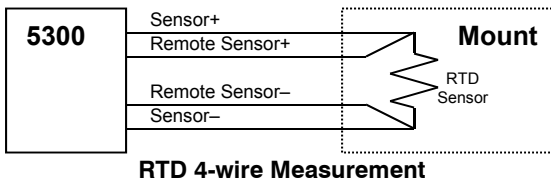
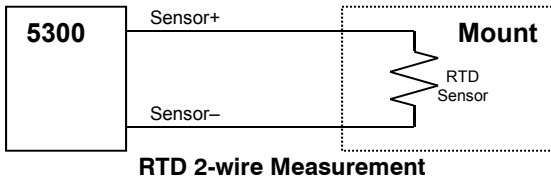

Because the Analog Set Point input shares the measurement input with the remote sensor input, when using RTD 4-wire measurement mode, the Analog Set Point Input is disabled.

User Calibration of Resistance Sensors

In some applications, having the ability to compensate, or calibrate, the sensor measurement is desired, such as referencing to an internal standard or to match the readings of another instrument. This is supported on the **TECSource** by using the TEC:USERCAL:PUT command to apply an offset and/or slope compensation to thermistor or RTD readings.

NOTE

The calibration is applied to the resistance measurement of the sensor, not the temperature. To adjust the resistance-to-temperature conversion, change the thermistor or RTD coefficients as needed.

To prevent accidental modification of the sensor calibration, calibration must first be enabled with the TEC:USERCAL:EDIT command. By default, the slope and offset values are 1.000 and 0.00, respectively, but can be adjusted to change the sensor measurement. The calibrated measurement is computed as follows:

$$\text{User calibrated reading} = \text{slope} * \text{reading} + \text{offset}$$

The offset is kilo-ohms (k Ω) for thermistors, and ohms (k Ω) for RTDs.

Be aware that the there is only a single set of calibration values, and changing sensor type does not change the calibration data. Therefore, if you will be changing between thermistor to RTD sensors, you will need to change the calibration values as appropriate for the new sensor setting. Changing the values back to 1.000 and 0.00 will return the instrument to factory calibration.

Controlling the Temperature Rate of Change

Some applications require that temperature is changed at a specific rate to prevent damage that might otherwise come from rapid changes in device temperature. Using the `TEC:TRATE` command, it is possible to control the temperature ramp rate of the controller, limiting the rate of change to specific degrees Celsius per minute.

Because the temperature rate function relies on the instrument tracking a gradually changing set point, a proper gain setting (or PID values) is important to achieve a smooth and continuous temperature transition.

To disable the temperature rate function, simply set the rate to 0 with a `'TEC:TRATE 0'` command.

External Fan Control

The **TECPak** has a built-in user adjustable DC power supply designed to provide up to 350mA to an external fan, such as those built into the **240 and 280 Series LaserMounts**. When using the **TECPak** with mounts that require a fan, no additional external power supply is needed, but a cable with appropriate wiring for the fan, such as the **1260B or 1262B TECSorce Cable**, must be used.

The fan is controlled via the `TEC:FAN` command, or via the **Settings...** dialog in **Arroyo Control**.

Speed can be set to *Off*, *Slow*, *Medium*, *Fast*, or a value between 4 and 12 (volts). When set to *Off*, the fan power is never turned on. *Slow*, *Medium*, and *Fast* correspond to 6.5V, 7.5V, and 8.5V, respectively.

There are five modes:

- 1 Fan is turned on whenever the TEC output is on, and turns off when the TEC output is turned off.
- 2 Fan is always on.
- 3 Similar to mode 1, the fan is turned on whenever the TEC output is on, but when the TEC is turned off, the fan will remaining running for an addition number of minutes as defined by the **Ext Fan Off** setting.
- 4 Fan is turned on whenever the TEC output is on and cooling, off otherwise.
- 5 Fan is turned on whenever the TEC output is on and heating, off otherwise.

When used, *Delay* is in minutes, and can be from 1 to 240.

Resistive Heaters and Heat/Cool Only Modes

The **TECPak** supports temperature control using resistive heaters instead of Peltier coolers. With resistive heaters, cooling is obviously not possible, and the **TECPak** must be configured to not attempt to cool the output, or a run-away condition will occur when the cooling current actually causes additional heating.

If your application requires, you can also configure the **TECPak** to operate in a cool-only mode. This is only possible with Peltier coolers.

To change the cooling mode, change Heat/Cool Mode setting in the **Settings...** dialog in **Arroyo Control**, or use the TEC:HEATCOOL command.

Gain Control and the PID Loop

The **TECPak** supports a fully configurable PID loop, allowing full customization of the PID control parameters. To simplify control, eight standard gain settings are also defined, and many applications can achieve acceptable performance with these predefined gain settings, eliminating the need to understand and adjust the PID loop.

The predefined gains are numbered 1 through 300, and set using the Gain setting in the **Settings...** dialog in **Arroyo Control**, or by using the TEC:GAIN command. Increasing the gain value will increase the speed of the control loop. For full access to the PID parameters, change the gain setting to *PID*, and the individual P, I, and D values can be set with the TEC:PID command.

The PID parameters function within a mathematical formula as described below:

$$\text{PID Formula: } \textit{Output} = P * \varepsilon + I * \sum \varepsilon dt + D * \frac{d\varepsilon}{dt}$$

Where ε is the error in the system, expressed as:

$$\varepsilon = \text{Target} - \text{Actual}$$

The controller can calculate ideal PID values using the AutoTune function, discussed in detail in the next section.

To manually adjust the PID, start by changing the I and D values to zero, and adjust the P value so that it reaches the set point as quickly as possible without overshooting the set point an unacceptable amount. Gradually increase the I

value until the set point is achieved without oscillation. In many systems, the D term is not needed and may be left at zero.

For additional information on PID loop tuning, consult online resources such as Wikipedia (http://en.wikipedia.org/wiki/PID_controller) or search for terms such as “Ziegler-Nichols method”, or “PID Loop”.

Using the AutoTune Function

The **TECPak** is capable of automatically determining PID parameters for most applications. Using a form of the Ziegler-Nichols method, the **TECPak** will step through a process to determine the thermal response of the mount, which can then be used in a mathematical model to calculate the PID parameters.

The PID parameters generated by AutoTune are not necessarily the *ideal* PID parameters, and small improvements may be possible by further refining the results manually.

Before starting the AutoTune function, it is best to begin from ambient conditions, either with the TEC off and the mount stabilized at ambient, or the TEC on and the set point around 25°C. While this is not required, it can produce better results. AutoTune only functions in temperature mode. PID parameters must be manually determined for R mode.

Make sure the current and temperature limits are set prior to starting AutoTune. AutoTune will intentionally cause your mount to oscillate, so the temperature limit should be at least 5 to 10 degrees away from the test point to avoid tripping a limit during the process.

The TEC:AUTOTUNE command starts the process, and requires one parameter, which is the AutoTune temperature test point. The command will immediately put the instrument into AutoTune mode. The TEC:AUTOTUNE? query can be used to monitor the process of AutoTune. A response of 1 indicates AutoTune is in progress. Once complete, the instrument will respond with a 2 if AutoTune failed or a 3 if AutoTune succeeded. A response of 0 is returned if the instrument has never started an AutoTune process.

The AutoTune process can take several minutes, and even longer on larger mounts with higher thermal mass.

Once the AutoTune process is complete, the output will remain on. If the AutoTune process fails, an E-436 AutoTune Failed error will be generated and the output turned off. Any of the following can cause the AutoTune to fail:

- Noisy temperature measurements, which make it difficult to accurately measure oscillations

- Any condition that causes the output to turn off (temperature limits, sensor limits, etc.)
- Systems with very low P or I terms

In the Auto-Tune fails due to thermal system limitations, you will need to manually modify the PID parameters as described in the section above or select factory gain setting.

Turning the output off remotely will cancel the AutoTune process and generate an E-436 error.

Compensating for Cable Resistance

Because the high currents the **TECPak** can drive through the Peltier, the voltage loss through the cable and connectors of the system can significantly affect the TEC voltage measurement. In most cases, accurate voltage measurements are not needed, and the default compensation of the instrument is sufficient. To improve the compensation, the **Cable R** setting allows you to specify the cable resistance, which is then used to dynamically subtract the voltage drop by using the formula $V = IR$ to calculate the voltage loss, where I is the TEC ITE current, and R is the **Cable R** setting. This value is then removed from the voltage measurement to display an accurate TEC voltage measurement.

The safest method of calculating cable resistance is to short the ITE+ and ITE– connections, making sure whatever you are using to short the terminals is not itself adding resistance to the circuit. Use short, heavy gauge wires, preferably soldered onto the terminals to minimize any resistance the short might add. Place the short as close to the Peltier as is reasonable. A simple approach is to unplug the cable from the mount and place a shorting plug on the mount end of the cable, which is easily made from a male DB15 connector and soldering the ITE+ and ITE– pins together. Make sure the Peltier is disconnected to protect it from current overloading during the test.

Change the instrument to ITE mode and set the current to 4A. Depending on your setup, you may first need to change the Mount to User Defined and adjust the limit to 4A. Turn on the output and after the voltage has stabilize, make a note of it and turn the output off. Enter the measured voltage into the following equation to calculate **Cable R**:

$$\text{Cable R} = \text{Voltage} / 4$$

The **Cable R** value can be changed using **Arroyo Control** or with the TEC:CABLER command. Typical values for **Cable R** are 0.008 to 0.040, but depend on your actual configuration.

Using the Analog Interface

The Analog Interface is a feature not found on our bench top temperature controllers, as it is designed to be used in applications where a user interface, or even a PC, is not required.

The Analog Interface has two sections: the logic level control/status pins, and the analog control/monitor pins, plus an auxiliary power supply. The +5V auxiliary supply is provided for external low-power electronics. Current draw on this supply must not exceed 100mA. The Ground pin provides the ground reference for both the logic level and analog inputs and outputs.

The logic level inputs operate off a low or high voltage input. A logic zero (below 1V) is considered to be off or false, while a logic one (above 2.5V, but do not exceed 5V) is considered to be on or true. For logic level outputs, a false will be 0V, while a true will be 3.3V.

CAUTION

Do not exceed 5V DC on any logic input pin or 3V DC on any analog input pin, or damage to the instrument may occur.

There are three logic level pins:

On/Off Control Input

This input controls the on/off state of the instrument. When this input transitions from off to on, then the TEC output is turned on, and begins controlling to the temperature set point. Similarly, when it transitions from on to off, the output is turned off.

It is possible to use the analog interface with the computer interface, as the **TECPak** is looking for a **change** in the logic input to turn the output on or off, as appropriate (considered an *edge* triggered input, rather than a *level* triggered input). It is possible for the computer interface to turn the output on or off as well, ignoring the steady state of the logic input. However, as soon as the logic input changes state, then the **TECPak's** output will also be changed to reflect the new state.

For example, if the logic input goes from false to true (turn the output on), then the output will be turned on. Later, if a TEC:OUT OFF is received from the computer (turn the output off), then the output will be turned off, *even though the logic input is still high*. Likewise, if the computer sends a TEC:OUT ON, the output will be turned on, regardless of the logic input's

state. Later, if the logic input goes from true to false, then the output will be turned off.

In this way, on/off operation can be supported simultaneously through the analog interface and the PC interface without conflict.

On/Off Status Output

This logic level output reflects the present output state of the instrument. When it is on and controlling the temperature, this output will be high.

Stable Status Output

The output is considered stable when the temperature has remained within the temperature band around the set point (as defined by the tolerance temperature) for a specific amount of time (as defined by the tolerance time). Once the temperature is considered stable, then this logic level output will be set to high. If the set point is changed, or a disturbance causes the actual temperature to fall outside the tolerance temperature, then this logic level output will be set to false, and the process starts over. The output will also be false whenever the output is off.

In addition, there are two analog signals: analog set point input, and analog monitor output.

CAUTION

The maximum allowable voltage input range on the analog input is -01V to +3V. Be sure not to exceed this range or damage to the instrument may occur.

Analog Set Point Input in Temperature (T) Mode

The analog set point input allows the user to change the temperature set point using a voltage signal. The voltage input range goes from 0V to 2.5V, and the transfer function is:

$$T_{\text{SETPOINT}} = (V / 2.5 * (T_{\text{ANALOG-HIGH}} - T_{\text{ANALOG-LOW}})) + T_{\text{ANALOG-LOW}}$$

Where V is the voltage input, in volts, and T_{SETPOINT} is the resulting temperature set point, in °C. $T_{\text{ANALOG-HIGH}}$ and $T_{\text{ANALOG-LOW}}$ can be adjusted using the TEC:ANALOG:THIGH and TEC:ANALOG:TLOW commands, respectively.

For example, if V was 1.00V, $T_{\text{ANALOG-HIGH}}$ was 200 and $T_{\text{ANALOG-LOW}}$ was -100, then T_{SETPOINT} would be 20°C:

$$T_{\text{SETPOINT}} = (1.00 / 2.5 * (200 - (-100))) + (-100), \text{ or}$$

$$T_{\text{SETPOINT}} = (1.00 / 2.5 * (200 + 100)) - 100 = 20$$

To achieve less sensitivity per °C, you can narrow the high and low temperature points to the actual operating range you need (perhaps $T_{\text{ANALOG-LOW}}$ of 10°C and $T_{\text{ANALOG-HIGH}}$ of 40°C, for example). In addition, you can change the resolution of the analog input from 1°C, 0.1°C, or 0.01°C, which is low the sensitivity to noise on the input. Both of these changes can be done using **Arroyo Control**, or via the `TEC:ANALOG:THIGH`, `TEC:ANALOG:TLOW`, or `TEC:ANALOG:RES` commands.

Because the Analog Set Point input shares the measurement input with the remote sensor input, when using RTD 4-wire measurement mode, the Analog Set Point Input is disabled.

Analog Set Point Input in Current (ITE) Mode

For TECPaks running firmware version 1.38 or later, the analog set point input allows the user to change the ITE set point using a voltage signal. The analog input function must be enabled with the `TEC:ANALOG:MODE` command, and the instrument set to ITE mode. When in this configuration, the ITE set point is ignored, and the ITE current is controlled exclusively via the analog input.

The voltage input range goes from 0V to 2.5V, and the transfer function is:

$$ITE_{\text{SETPOINT}} = ITE_{\text{LIMIT}} * (V - 1.25)$$

Where V is the voltage input, in volts, and ITE_{SETPOINT} is the resulting current set point, in Amps. As can be seen from this equation, the full range of the analog input corresponds to $-ITE_{\text{LIMIT}}$ to $+ITE_{\text{LIMIT}}$, so the sensitivity of the input function can be adjusted by raising or lowering the limit.

Because the Analog Set Point input shares the measurement input with the remote sensor input, when using RTD 4-wire measurement mode, the Analog Set Point Input is disabled.

Analog Monitor Output

The second analog signal is a monitor output that produces a voltage output that tracks the actual voltage across the sensor. Because the bias current is fixed, the actual sensor resistance can be easily calculated using Ohm's Law, and then using the Steinhart-Hart formulas, the actual temperature can then be calculated.

First, to calculate the actual sensor resistance, you need to take the voltage output and *multiply it by two*. This is because the output voltage goes through a divide-by-two circuit before being output, and you need to double it to return it to the actual voltage. Then, the resistance of the sensor is calculated as follows:

$$R_{\text{SENSOR}} = \text{Analog Mon Out} * 2 / \text{BiasCurrent}$$

The bias current is either 10uA or 100uA for thermistors, or 1 mA for RTDs.

Once the resistance is known, then the temperature can be calculated using the appropriate equation discussed in the thermistor and RTD sections above.

If you wish to make a highly accurate measurement, then you will need to calibrate the voltage reading from the instrument. You can do this using two known fixed resistor values, measuring the Analog Monitor Output for each resistor and calculating the calibration coefficients for a simple linear equation to correct for any measurement error. Contact the factory for a self-guided Excel worksheet that will capture the values and perform the calculations for you.

Connecting to the Analog Interface

Connecting to the Analog Interface is very straightforward. Because the inputs and outputs are buffered, you do not need any external filters or buffers, unless your application requires it. The logic level interfaces are all high impedance, as is the Analog Set Point Input. The Analog Monitor Output is an op-amp driven through a 1kΩ resistor to protect against output shorting.

A typical application might look like this:

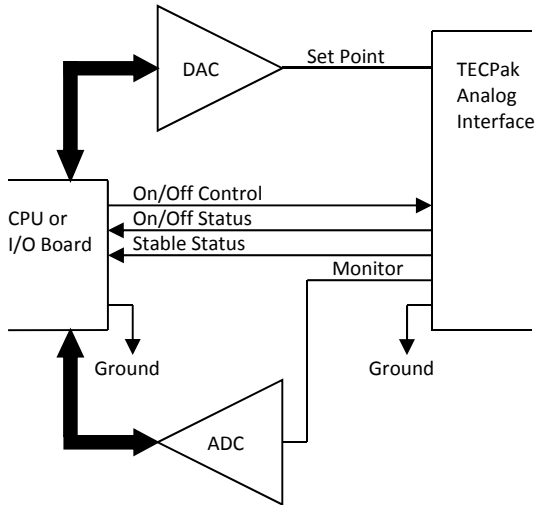

Specifications

All values relate to a one-hour warm-up period.
Specifications for standard models. Custom models may vary.

Description	585-04-08	585-05-12
Drive Channel		
Current		
Range (A)	4	5
Compliance Voltage (V)	8	12
Max Power (W)	28	55
Resolution (A)		0.01
Accuracy (+/- [% set point + mA])		0 + 30
Noise/Ripple (mA, rms)		< 5
Temperature Control		
Range (°C) ¹		-99 to 250
Resolution (°C)		0.01
Thermistor Accuracy (\pm °C) ²		0.05 ³
Short Term Stability (1hr) (\pm °C) ⁴		0.004
Short Term Stability (24hr) (\pm °C) ⁴		0.01
Measurement Channels		
Current		
Resolution (mA)		10
Accuracy (+/- [% reading + mA])		0 + 30
Voltage		
Resolution (mV)		10
Accuracy (+/- [% reading + mV])		0 + 50
Sensor		
<i>10μA Thermistor</i>		
Range (k Ω)		0.1 - 450
Resolution (Ω)		10
Accuracy (+/- [% reading + Ω])		0.05 + 50
<i>100μA Thermistor</i>		
Range (k Ω)		0.05 - 45
Resolution (Ω)		1
Accuracy (+/- [% reading + Ω])		0.05 + 5

¹ Software limits. Actual range dependent on sensor type and system dynamics

² Accuracy figures are the additional error the 5300 adds to the measurement, and does not include the sensor uncertainties.

³ 25°C, 100 μ A thermistor

⁴ Stability measurements done at 25°C using a 10k Ω thermistor on the 100 μ A setting. The number is $\frac{1}{2}$ the peak-to-peak deviation from the average over the measurement period.

<i>RTD</i>	
Range (Ω)	20 – 192
Resolution (Ω)	0.01
Accuracy (+/- [% reading + Ω])	0.03 + 0.1
Current Limit	
Resolution (mA)	10
Accuracy (+/- mA)	50
Other	
Fan Supply	4 – 8.5V, 350mA max
TEC Connector	Female DB-15
Computer Interface	USB 2.0 Full Speed (Type B), RS-232 (DB-9, male)
Power	90 – 240 V, 50/60 Hz 50W 85W
Size (H x W x D) [inches (mm)]	3.0 (77) x 4.5 (115) x 8.5 (216)
Weight [lbs (kg)]	
Operating Temperature	+10°C to +40°C
Storage Temperature	-20°C to +60°C

Error Messages

Error Code	Description	Cause
E-100	General Error	The error code is non-specific, and is generally used when no other error code is suitable.
E-102	Message too long	The message is too long to process (USB/Serial only).
E-104	Type not allowed	The RADix type was invalid
E-123	Path not found	The message used an invalid path command (USB/Serial only).
E-124	Data mismatch	The message contained data that did not match the expected format (USB/Serial only).
E-126	Too few or too many elements	The command requires more or less than the number of parameters actually supplied.
E-127	Change not allowed	An attempt was made to change a parameter that cannot be changed, or is currently read-only.
E-201	Data out of range	The message attempted to set a value that was outside the allowable range (USB/Serial only).
E-202	Invalid data type	When trying to parse the message, the data was in an invalid format (USB/Serial only).
E-204	Suffix not valid	An invalid number base suffix (radix) was encountered when parsing a number (USB/Serial only).
E-402	Sensor open, output turned off	A sensor open circuit was detected and the output was turned off.
E-403	Module open, output turned off	A Peltier module open circuit was detected and the output was turned off.
E-404	I limit, output turned off	A current limit was detected and the output was turned off.
E-405	V limit, output turned off	A voltage limit was detected and the output was turned off.
E-406	Sensor limit, output turned off	The sensor limit (high or low) was exceeded and the output was turned off.
E-407	Temperature limit, output turned off	The temperature limit (high or low) was exceeded and the output was turned off.
E-409	Sensor changed, output turned off	The sensor type was changed, causing the output to be turned off.
E-410	Temperature was out of tolerance, output turned off	The temperature went out of tolerance and the output was turned off.

Error Code	Description	Cause
E-415	Sensor short, output turned off	A sensor short circuit was detected and the output was turned off.
E-416	Cal failed	An error occurred during calibration that caused the calibration to fail. The unit is no longer in calibration mode.
E-419	TEC not stable	The TEC is considered stable if the temperature has changed less than 0.02°C for more than 20 seconds.
E-433	Not a TEC	The TEC:CHAN command attempted to select a non-TEC channel
E-434	Ite limit exceeds cable rating	The cable plugged into the unit is not rated to carry the current as set by the current limit. Use a 1262 cable, 1262 cable, or custom cable with ID pin connected to analog ground, or reduce the current limit below 5A.
E-435	Mode Change	A mode change occurred when the output was on, forcing the output off.
E-997	Control error, cycle power	A hardware control error occurred, cycle power to resolve. If error continues to occur, contact factory.
E-998	Command not supported	A command was received that is not supported by this instrument.
E-999	Non-specific error	A non-specific error was encountered.

Calibration, Maintenance and Service

Calibration

Arroyo Instruments recommends the annual calibration of the **TECPak** to ensure conformance to the published specifications, or as dictated by your quality system. Arroyo Instruments offers NIST-traceable calibration services with data. Contact the factory for more details.

Maintenance

The **TECPak** requires no regular maintenance other than product calibration. To clean the instrument, use cotton cloth that is only damp (not wet) with a very light solution of soap and water.

Fuses

Under normal operation, you should never need to replace a fuse. However, if either fuse does blow, use only T 250V, 1.0A, IEC 60127-2 5x20mm metric fuses as replacements. If, after replacing the fuse, it continues to blow, immediately discontinue use of the instrument and contact service for support.

Service

Service and repair for the **TECPak** can be obtained by contacting the distributor from where you purchased the instrument, or directly from Arroyo Instruments. A complete list of distributors is available on the Arroyo web site.

You can contact Arroyo Instruments through one of these methods:

By mail:	Arroyo Instruments 1201 Prospect Street San Luis Obispo, CA 93401 USA
By phone:	+1 (805) 543-1302
By fax:	+1 (805) 543-1303
By email:	support@arroyoinstruments.com
On the web:	http://www.arroyoinstruments.com

In all cases, Arroyo Instruments requires a return materials authorization (RMA) number. You must contact Arroyo Instruments and obtain an RMA number prior to returning your instrument, or the shipment may be rejected and sent back to you.

Warranty

Arroyo Instruments warrants that this product will be free from defects in material and workmanship and will comply with Arroyo Instruments' published specifications at the time of sale for a period of one year from date of shipment. If found to be defective during the warranty period, the product will either be repaired or replaced at Arroyo Instruments' option.

To exercise this warranty, write or call your local Arroyo Instruments representative, or contact the factory directly at the address given above. You will be given prompt assistance and return instructions. Send the product, freight prepaid, to the indicated service facility. Repairs will be made and the instrument returned freight prepaid. Repaired products are warranted for the balance of the original warranty period or 90 days, whichever first occurs.

Limitation of Warranty

The above warranties do not apply to products which have been repaired or modified without Arroyo Instruments' written approval, or products subjected to unusual physical, thermal or electrical stress, improper installation, misuse, abuse, accident or negligence in use, storage, transportation or handling. This warranty also does not apply to fuses, batteries, or damage from battery leakage.

THIS WARRANTY IS IN LIEU OF ALL OTHER WARRANTIES, EXPRESSED OR IMPLIED, INCLUDING ANY IMPLIED WARRANTY OF MERCHANTABILITY OR FITNESS FOR A PARTICULAR USE. ARROYO INSTRUMENTS SHALL NOT BE LIABLE FOR ANY INDIRECT, SPECIAL, OR CONSEQUENTIAL DAMAGES RESULTING FROM THE PURCHASE OR USE OF ITS PRODUCTS.

European Community Declaration of Conformity

EC Declaration of Conformity



I/We

Arroyo Instruments

of

1201 Prospect Street
San Luis Obispo, CA
USA

declare that

585 Series TECPak

In accordance with the following directives

EMC Directive: 89/336/EEC
Low Voltage Directive: 73/23/EEC
RoHS Directive: 2002/95/EC89/336/EEC

has been designed and manufactured to the following specifications:

EMC Directive Test Standards

EN 61326 Electrical Equipment for Measurement, Control and Laboratory Use EMC Requirements. This encompasses 10 individual Tests

Low Voltage Directive Test Standards

EN 61010 Electrical Equipment for Measurement, Control and Laboratory Use Safety Requirements.

This Certificate is the Manufacturer's Declaration which states that the **6300 Series ComboSource Laser Diode Controller** is Compliant to the above noted EU Directives and are therefore, eligible to bear the CE MARK. This equipment, as of the listed Date of Manufacture, is technically exempted from the RoHS Directive Requirements, not being classified as consumer electronics equipment.

I hereby declare that the equipment named above has been designed to comply with the relevant sections of the above referenced specifications. The unit complies with all essential requirements of the Directives.

Paul Corr
(NAME OF AUTHORIZED PERSON)

(SIGNATURE OF AUTHORIZED PERSON)

President
(TITLE OF AUTHORIZED PERSON)

June 1, 2011
(DATE OF ISSUE)



1201 Prospect Street, San Luis Obispo, CA 93401

Tel: (805) 543-1302 Fax: (805) 543-1303

sales@arroyoinstruments.com

www.arroyoinstruments.com